

Reg No.: _____

Name: _____

APJ ABDUL KALAM TECHNOLOGICAL UNIVERSITY
Second Semester B.Tech Degree Examination July 2021 (2019 scheme)

**Course Code: EST110****Course Name: ENGINEERING GRAPHICS****(2019 Scheme)**

Max. Marks: 100

Duration: 3 Hours

Instructions: Retain Construction lines. Show necessary dimensions. Answer any ONE question from each module. Each question carries 20 marks

Module-I

- 1 The front view of line AB is 50° inclined to XY line and is 55 mm long while its top view is 60° inclined to XY line. If end A is 10 mm above HP and 20 mm in front of VP, draw its projections. Find the true length and inclinations of line with HP and VP.
- 2 The end point A of a line is 20 mm above HP and 10mm in front of VP. The other end of the line is 50 mm above HP and 15 mm behind VP. The distance between the end projectors is 70 mm. Draw the projections of the line. Find the true length and true inclinations of the line with the principal planes. Also locate the traces of the line.

Module-II

- 3 A square pyramid of base 25 mm. side and axis 60 mm long, has a corner of the base on the ground such that the square base is inclined at 30° to the ground and the two base edges containing that corner are equally inclined to HP. Draw the projections of the pyramid if its axis is inclined at 60° to the VP.
- 4 A cylinder 40 mm diameter and 50 mm axis is resting on a point of its base circle on VP while its axis makes 45° with VP and front view of the axis makes 35° with XY line. Draw its projections

Module-III

- 5 A hexagonal pyramid side of the base 30 mm and axis 70 mm rests with its base on the HP and an edge of the base inclined at 30° to VP. A section plane inclined at 45° to VP and perpendicular to HP passes through the pyramid at a distance of 10 mm from the axis and in front of it. Draw its top view, sectional front view and true shape of section.
- 6 A pentagonal prism side of base 25 mm and altitude 50 mm, rests on its base on the

00EST110121905

HP such that an edge of the base is parallel to VP and nearer to the observer. It is cut by a plane inclined at 45° to HP, perpendicular to VP and passing through the centre of the axis. Draw the development of the surface of the truncated prism.

Module-IV

- 7 Draw the isometric view of a pentagonal pyramid, side of base 20 mm and height 50 mm which rests centrally with base on a cylinder of diameter 60 mm and height 40 mm.
- 8 A hollow cylinder of inside diameter 40 mm, outside diameter 60 mm and 80 mm long is resting on its generator on the top of a rectangular slab of 80 mm x 60 mm and height 30 mm. Draw the isometric view of the combination if the axis of the cylinder is parallel to the longer edges of the slab.

Module-V

- 9 A pentagonal prism of base sides 30 mm and length 70 mm is resting on one of its rectangular faces on the ground, behind the Picture Plane (PP) and one pentagonal face touching the PP. The station point is 65 mm in front of the PP, 30 mm above the ground, and 80 mm to the right of the axis of the prism. Draw its perspective view.
- 10 Draw the top view, front view and any one side view of the figure shown below. The front view direction is marked with a long arrow.

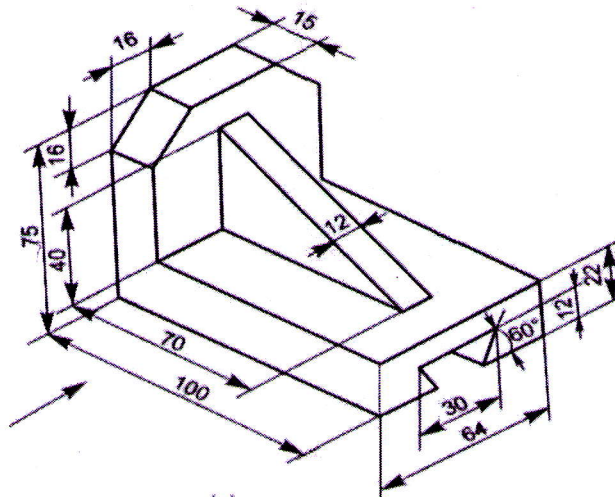

(20x5=100 Marks)
