

Reg No.: \_\_\_\_\_

Name: \_\_\_\_\_

03000EE306052003

APJ ABDUL KALAM TECHNOLOGICAL UNIVERSITY

Sixth Semester B.Tech Degree Regular and Supplementary Examination July 2021



Course Code: EE306

Course Name: POWER SYSTEM ANALYSIS

Max. Marks: 100

Duration: 3 Hours

**PART A**

*Answer all questions, each carries 5 marks.*

Marks

- |   |  |     |
|---|--|-----|
| 1 | Derive the relation for computation of unbalanced voltage vector from their symmetrical components.  | (5) |
| 2 | What are the different types of faults in power system and effects of fault?   | (5) |
| 3 | Classify the different types of buses in a power system.   | (5) |
| 4 | What are the main components of a speed governor system?   | (5) |
| 5 | What are the constraints of unit commitment? Explain the thermal unit constraint.  | (5) |
| 6 | Derive the equation for penalty factor for optimal system operation.   | (5) |
| 7 | Derive swing equation.   | (5) |
| 8 | A 50Hz, 4 pole turbogenerator of rating 20 MVA, 13.2 kV has an inertia constant of $H=9\text{kW-sec/ kVA}$ . Find the kinetic energy stored in the rotor at synchronous speed. | (5) |

**PART B**

*Answer any two full questions, each carries 10 marks.*

- 9 The single line diagram of an unloaded power system is shown in figure. The generator and transformer are rated as: (10)
- $G1=20\text{MVA}, 13.8\text{kV}, X''=20\%$ ;  $G2=30\text{MVA}, 18\text{kV}, X''=20\%$ ;  
 $G3=30\text{MVA}, 20\text{kV}, X''=20\%$ ;  $T1=25\text{MVA}, 220/13.8\text{kV}, X=10\%$ ,  
 $T2=3$  single phase units each rated at  $10\text{MVA}, 127/18\text{kV}, X=10\%$ ,  
 $T3=35\text{MVA}, 220/22\text{kV}, X=10\%$ .
- Draw the reactance diagram using a base of 50 MVA and 13.8kV on generator G1.

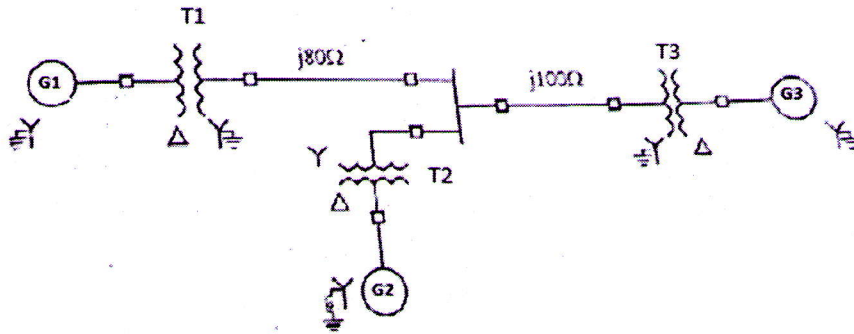

- 10 a) Draw the zero sequence, negative sequence and positive sequence network of a generator grounded through a reactance. (4)
- b) What are current limiting reactors and its location? (3)
- c) A generator rated at 30 MVA, 11 kV has a reactance of 20%. Calculate its p.u. reactance for a base of 50MVA and 10kV. (3)
- 11 a) Derive the expression for fault current for a single line to ground fault occurring in an unloaded generator. Also draw the interconnection of sequence network. (6)
- b) A salient pole generator without dampers is rated 20 MVA , 13.8 kV and has a direct axis subtransient reactance of 0.25 per unit. The negative and zero sequence reactance are 0.35 and 0.1 per unit respectively. The neutral of the generator is solidly grounded. Determine the actual value of subtransient current in the generator when a single line-to- ground fault occurs at the generator terminals with generator operating unloaded at rated voltage. Neglect resistance. (4)

**PART C**

*Answer any two full questions, each carries 10 marks.*

- 12 The line admittance of a 4-bus system are as under:

Bus code	1-2	1-3	2-3	2-4	3-4
Admittance	2-j8	1-j4	0.666-j2.664	1-j4	2-j8

The schedule of active and reactive powers is:

Bus code	P	Q	V
1	--	--	1.06∠0
2	0.5	0.2	--
3	0.4	0.3	--
4	0.3	0.1	--

(10)

Form  $Y_{BUS}$  and compute the voltage at bus 2 at end of first iteration using G-S method. Take  $\alpha=1.6$

- 13 a) Explain the significance of load flow study. (4)  
b) With a neat block diagram explain the automatic voltage regulator of a generator. (6)
- 14 Derive the block diagram representation of generator – load model and explain the load frequency control of an isolated power system. (10)

**PART D**

*Answer any two full questions, each carries 10 marks.*

- 15 a) A power plant has 3 units with the following cost curves:  
 $C_1 = P_1^2 + 430 P_1 + 10000$  Rs/hour  
 $C_2 = 2 P_2^2 + 540 P_2 + 10000$  Rs/hour  
 $C_3 = 1.4 P_3^2 + 320 P_3 + 18000$  Rs/hour (7)  
Maximum and minimum generation for each unit is 120MW and 36MW. Find the optimum scheduling for a total load of 200 MW.
- b) What is incremental fuel cost? Give its significance in economic load scheduling problem. (3)
- 16 a) Explain the equal area criterion for transient stability analysis. (6)  
b) Draw fuel-cost curve and explain. (4)
- 17 a) Give the simplified power angle equation and the expression for  $P_{max}$ . Also draw the power angle curve. (4)  
b) Define inertia constant. (2)  
c) What are the methods of improving transient stability? (4)

\*\*\*\*