

Reg No.: _____

Name: _____

APJ ABDUL KALAM TECHNOLOGICAL UNIVERSITY
 B.Tech S1 (Special Improvement) Examination January 2021 (2019 scheme)

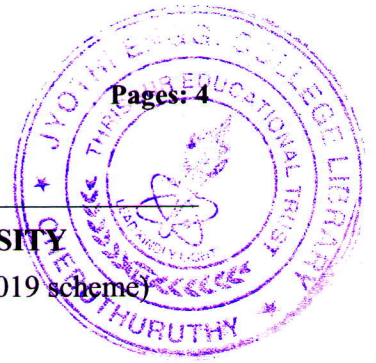

Course Code: EST100

Course Name: ENGINEERING MECHANICS
(2019-Scheme)

Max. Marks: 100

Duration: 3 Hours

PART A*(Answer all questions, each carries 3 marks.)*

- 1 A traffic signal of mass 500 N is hung with the help of two strings, as shown in **fig (Q1)** below. Find the forces induced in the strings using Lami's theorem. (3)
- 2 State and explain the conditions of equilibrium of coplanar concurrent force system. (3)
- 3 Three forces 20N, 30N and 40N act along AB, BC and CA respectively, the three sides of an equilateral triangle ABC. Find the resultant. (3)
- 4 A block shown in **Fig (Q2)** is just moved by a force of 200 N. The weight of the block is 600 N. Determine the coefficient of static friction between the block and the floor. (3)

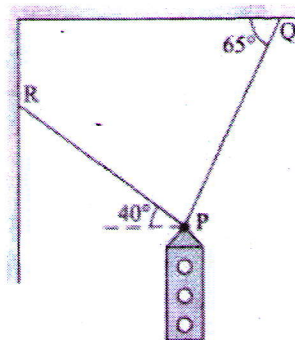
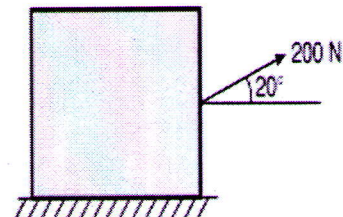
**Fig. (Q1)****Fig. (Q2)**

- 5 Write down the expression for centroid of a rectangle about a line passing through its base. (3)
- 6 A force $F = 2\hat{i} + 3\hat{j} - 4\hat{k}$ is applied at the point B(1,-1,2). Find the Moment of inertia of the force about a point A. (3)
- 7 The angular acceleration of a particle $\alpha = 5t \text{ rad/s}^2$. Determine expression for angular velocity ' ω ' at any instant ' t ' of the motion, if the particle starts from rest. (3)
- 8 A force of 300N acts on a body of weight 500N. Find the acceleration of the body by using D'Alembert's principle. (3)
- 9 A body performing Simple Harmonic Motion has an amplitude of 1m and a period of oscillation 2.05 seconds. Find the velocity and acceleration of the body (3)

4 seconds after passing the mean position.

- 10 A solid circular disc of mass 10 kg and radius 0.3m is rotating about its centre (3)
with constant angular acceleration of 10 rad/s^2 . Determine the torque acting on
the disc.

PART B

(Answer one full question from each module, each question carries 14 marks)

Module-I

- 11 Two rollers each of weight 75 N are supported by an inclined plane and a (14)
vertical wall. Find the reaction at the points of contact A, B, C. Assume all the
surfaces to be smooth. **Fig. (Q 11a)**
- 12 ABCD is a square of side 6 m. Forces acting along AB, BC, CD, DA, AC and (14)
DB are 1.5 kN, 3 kN, 12 kN, 7.5 kN, $7.5\sqrt{2}$ kN, $3\sqrt{2}$ kN respectively. Find the
resultant force and resultant moment about D. **Fig (Q11b)**

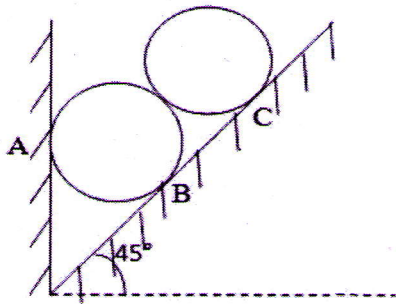

Fig. (Q 11a)

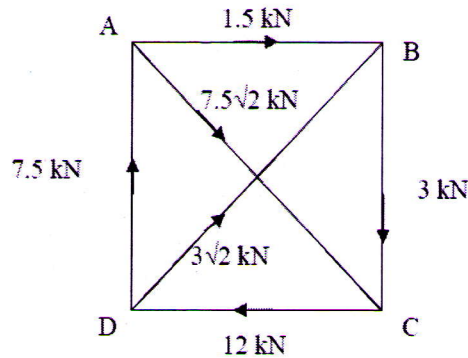
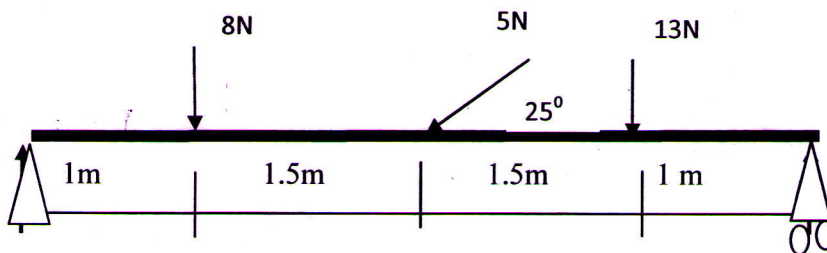

Fig. (Q 11b)

Module-II

- 13 a) What do you understand by the reactions at supports? (4)
Find the reactions at the supports of the beam given. A is a hinged support and B (10)
is a roller support



- 14 Two wedges A and B are used to raise another block C weighing 1000 N as (14)
shown in figure. Assuming coefficient of friction as 0.25 for all surfaces,
determine the value of P for impending upwards motion of C shown in **fig (Q14)**

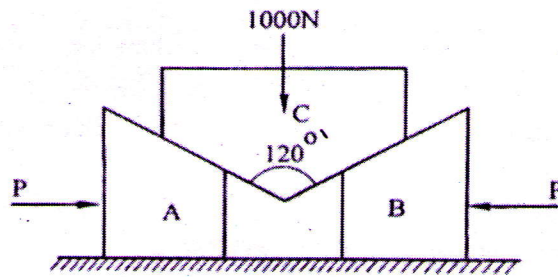

Fig. (Q14)

Module-III

- 15 A rectangular concrete slab supports loads in kN at its four corners as shown in Fig (Q15). Determine the resultant and the point of application of the resultant. (14)

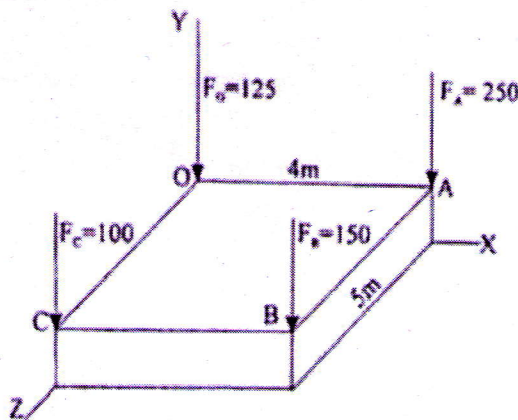

Fig (Q15)

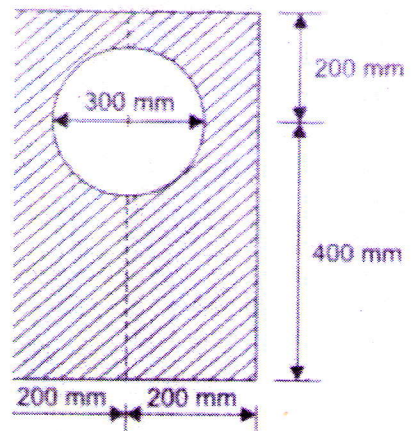

Fig (Q16)

- 16 Find the moment of inertia of a plate with a circular hole in Fig (Q16) about its centroidal horizontal and vertical axes. Also calculate the radius of gyration about the x-axis. (14)

Module-IV

- 17 a) Explain how you can apply Work – Energy Principle in Dynamics (5)
 b) Two blocks of 100N (A) and 50N (B) are connected by a flexible but inextensible string as shown in figure (Q17b). Assuming coefficient of friction between block 100N and horizontal surface is 0.25, find the acceleration of masses and tension in the string. (9)

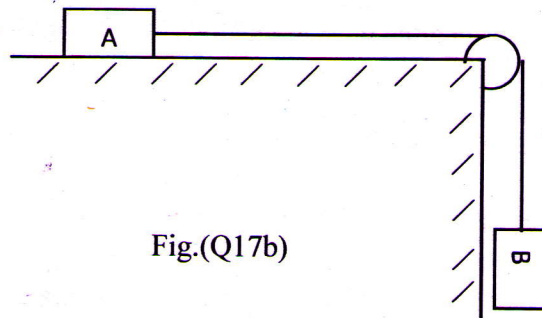

Fig.(Q17b)

- 18 a) A car starts from rest on a curved road of radius 600m and acquires by the end of the first 60 seconds of motion a speed of 24kmph. Find the tangential and normal acceleration at the instant, $t = 30$ s. Also calculate the distance covered at the end of first 30 seconds. (5)
- b) With what minimum horizontal velocity u can a boy throw a rock at A and have it just clear the obstruction at B? (Fig Q18b) (9)

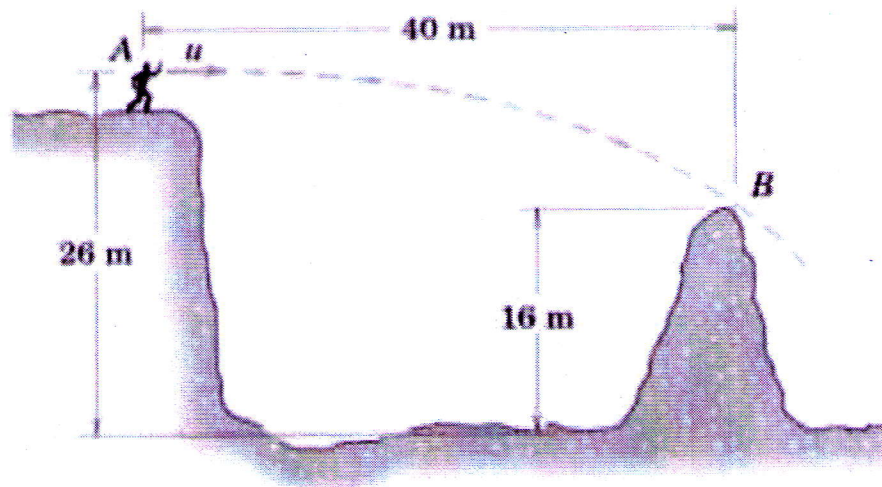

Fig (Q18b)

Module-V

- 19 a) A flywheel rotates with a constant retardation due to breaking, in the first 10 seconds, it made 300 revolutions. At $t = 7.5$ sec, its angular velocity was 40π rad/s. Determine (7)
- The value of constant retardation
 - The total time taken to come to rest and
 - The total revolutions made till it comes to rest
- b) Two blocks of masses 10 kg and 25 kg are attached to the two ends of a flexible rope. The rope passes over a pulley of diameter 500mm. The mass of the pulley is 7.5 kg and its radius of gyration is 200 mm. Find the acceleration of the masses and the tension on either side of the rope. (7)
- 20 a) A spring stretches by 0.015m when a 1.75kg object is suspended from its end. How much mass should be attached to the spring so that its frequency of vibration is 3 Hz. (7)
- b) A particle has SHM. Its maximum velocity is 6m/s and maximum acceleration is 12 m/s^2 . Determine the angular velocity and amplitude. Also determine its velocity and acceleration when displacement is half of the amplitude. (7)
