

Reg No.: _____

02000EE201092002 Name: _____

APJ ABDUL KALAM TECHNOLOGICAL UNIVERSITY

Third semester B.Tech examinations (S) September 2020

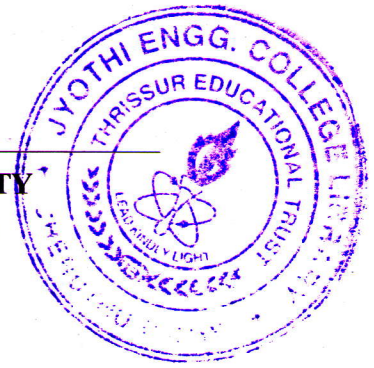

Course Code: EE201

Course Name: CIRCUITS AND NETWORKS

Max. Marks: 100

Duration: 3 Hours

PART A

Answer all questions, each carries 5 marks.

Marks

- 1 Compute the power dissipated in the 2Ω resistance in the network shown below, (5)
using superposition principle. Assume all the active sources as ideal.

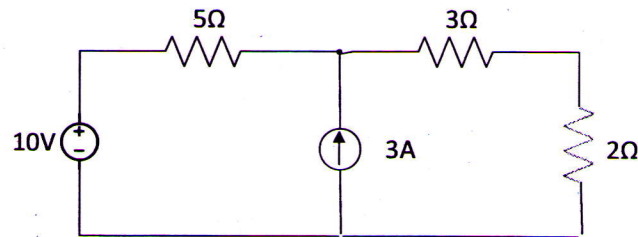

- 2 Define the following terms with an example: (i) Graph (ii) Directed graph (5)
(iii) tree (iv) link (v) twig
- 3 A series RC circuit has $R=10\Omega$ and $C=1F$. If the circuit is connected to a 10V (5)
DC supply at time $t=0$, determine (i) the time at which the voltage across the
capacitor is 5V and (ii) the circuit current at that instant.
- 4 The switch K in the circuit given below has been at position 1 for a long time. (5)
At $t = 0$, the switch is moved to position 2. Determine the current flowing
through the 1Ω resistance for $t \geq 0$ using Laplace transform technique.

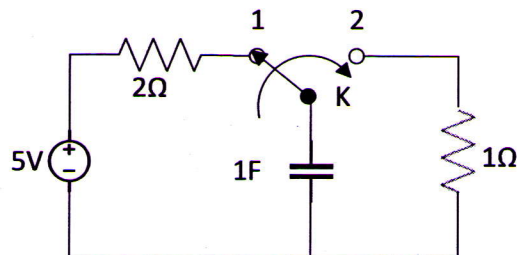

- 5 What is ABCD parameters? Why are they called transmission parameters? (5)
- 6 Show that for a two-port network $[Y]=[Z]^{-1}$. (5)
- 7 State the properties of Hurwitz polynomials. (5)

- 8 Determine whether the following function is a positive real function. (5)

$$F(s) = \frac{s+2}{s+1}$$

PART B

Answer any two full questions, each carries 10 marks.

- 9 Determine the voltage drop across the 8Ω resistance in the circuit given below, (10)
using Norton's theorem. Also calculate the power dissipated in the resistance.

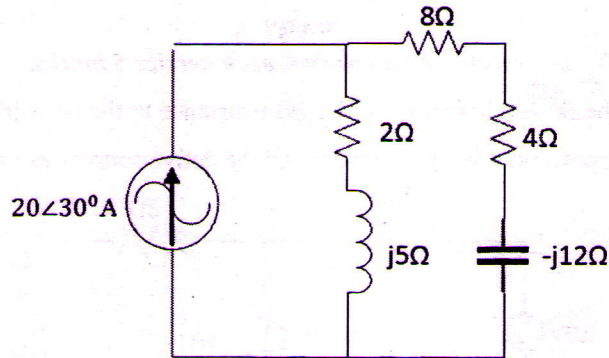

- 10 a) State reciprocity theorem. Verify reciprocity theorem for the circuit given below. (5)

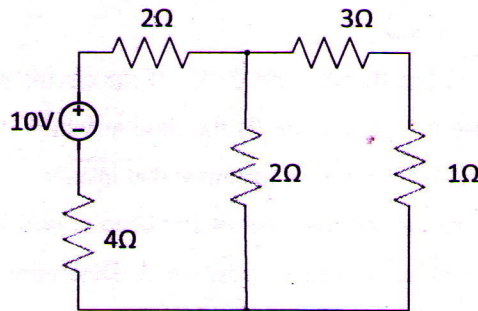

- b) Draw the oriented graph for the reduced Incidence matrix given below. (5)

$$A = \begin{bmatrix} 1 & 1 & 0 & 0 & 0 \\ -1 & 0 & 1 & 0 & 1 \\ 0 & 0 & -1 & -1 & 0 \end{bmatrix}$$

- 11 For the network shown in the figure write down the cut-set matrix and determine all branch voltages. (10)

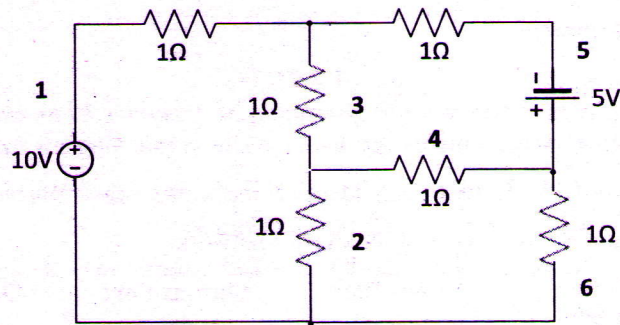

PART C

Answer any two full questions, each carries 10 marks.

- 12 The circuit shown in the figure is initially at steady state, with the switch K (10)
 opened. If the switch is closed at time $t = 0$, determine the expression for the
 voltage across the capacitor for $t \geq 0$. Also find its final steady state value.

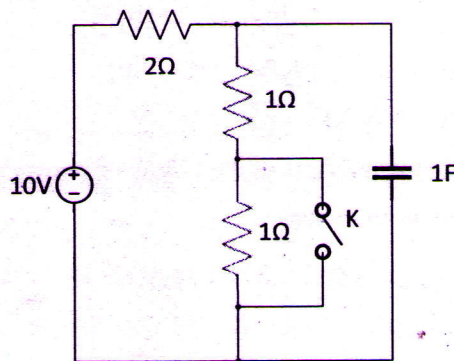

- 13 a) A series RL circuit with $R = 10\Omega$ and $L = 2H$ is connected to a 20V DC supply (5)
 at time $t = 0$. Plot the variation of inductor current and voltage across the
 resistor for $t \geq 0$ by deriving the expression for the same.
 b) Determine the loop current I_2 in the circuit given below. (5)

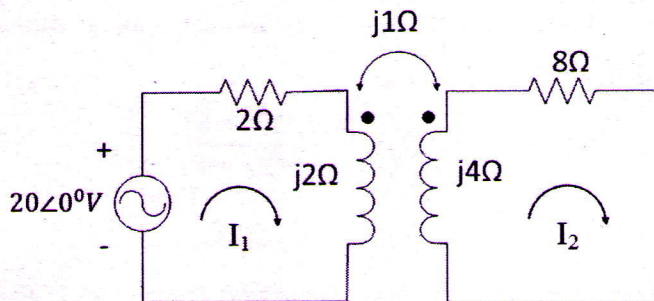

- 14 A series RLC circuit with $R = 5\Omega$, $L = 1H$ and $C = 0.25F$ is connected to a (10)
 10V DC supply at time $t = 0$. Determine the expression for (i) the current $i(t)$

through the circuit and (ii) voltage across the capacitor $v(t)$. Use Laplace transform technique.

PART D

Answer any two full questions, each carries 10 marks.

- 15 a) The following measurements are taken while conducting an experiment on a two port network. If two such identical networks are connected in parallel, determine the Y parameters of the overall network. (5)

Input port terminals shorted	Input Port Current	Output Port Voltage	Output Port Current
	-2A	10V	5A
Output port terminals shorted	Input Port Voltage	Input Port Current	Output Port Current
	5V	2.5A	-1A

- b) The port currents of a two port network are given by (5)

$$I_1 = 4V_1 - 2V_2$$

$$I_2 = -2V_1 + 5V_2$$

Find the equivalent π network.

- 16 a) Find the transmission parameters of the following network and hence determine whether the network is reciprocal. (5)

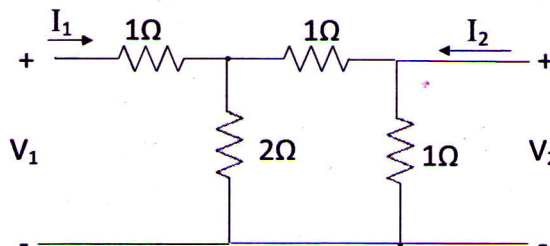

- b) List any five properties of LC driving point immittance functions. (5)
- 17 Synthesize the Foster I and II forms of RC network with the following driving point function. (10)

$$Z(s) = \frac{(s + 1)(s + 6)}{s(s + 4)(s + 8)}$$
