

Reg No.: _____

Name: _____

APJ ABDUL KALAM TECHNOLOGICAL UNIVERSITY

Seventh semester B.Tech examinations (S), September 2020



Course Code: EC409

Course Name: CONTROL SYSTEMS

Max. Marks: 100

Duration: 3 Hours

PART A

Answer any two full questions, each carries 15 marks.

- | | | |
|------|--|------|
| 1 a) | Compare open loop and closed loop system with suitable examples. | (5) |
| b) | Find the transfer function using Mason's gain equation | (10) |

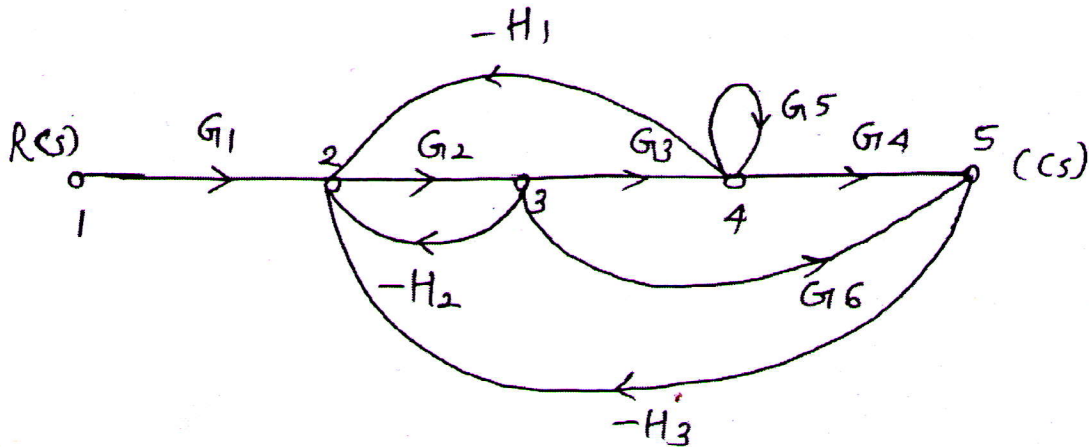

- | | | |
|------|---|------|
| 2 a) | Determine the rise time, peak time, settling time and peak overshoot of a second order control system subjected to a unit step input. The damping ratio = 0.5 and undamped natural frequency $\omega_n = 6 \text{ rad/sec}$. | (5) |
| b) | Derive an expression for rise time of a second order system. | (5) |
| c) | Derive an expression for time response of a second order under damped system to step input. | (5) |
| 3 a) | Find the transfer function of the given system using block reduction technique | (10) |

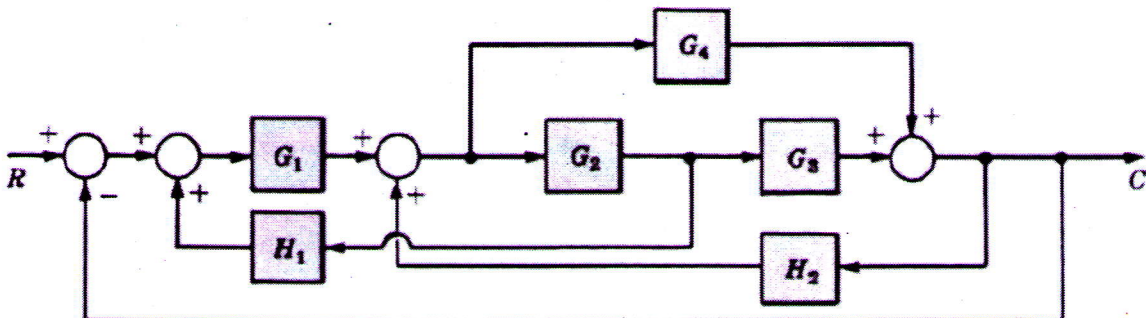

- b) The block diagram of a unity feedback (negative) system is shown in figure. Determine the steady state error for unit ramp input when $K=400$. Also determine the value of K for which the steady state error to unit ramp will be 0.02 (5)

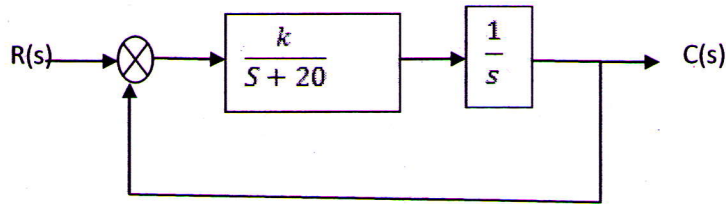

PART B

Answer any two full questions, each carries 15 marks.

- 4 a) Comment on the stability of the system whose characteristic equation is given by (5)
 $s^5 + 2s^4 + 3s^3 + 6s^2 + 2s + 1 = 0$.
- b) A unity feedback control system has an open loop transfer function (10)
 $G(s) = K(s+9) / s(s+3)(s+5)$. Sketch the root locus.
- 5 a) Compare PI, PD and PID controllers. (5)
- b) Sketch the bode plot for the following transfer function and determine phase margin and gain (10)
margin. $G(s) = \frac{75(1+0.2s)}{s(s^2+16s+100)}$.
- 6 a) Draw the Nyquist plot for the system whose open loop transfer function is (8)
 $G(s)H(s) = \frac{K}{s(s+2)(s+10)}$. Determine the range of K for which the closed loop system is stable.
- b) Describe the design procedure of a lag compensator. (7)

PART C

Answer any two full questions, each carries 20 marks.

- 7 a) A linear system representation in state space is given as (5)

$$X = \begin{bmatrix} 0 & 1 & 0 \\ 0 & 0 & 1 \\ 0 & -2 & -3 \end{bmatrix} X + \begin{bmatrix} 0 \\ 0 \\ 1 \end{bmatrix} r$$

$$y = [2 \quad 2 \quad 2]$$
Apply Kalman's test to find whether the system is completely observable.
- b) A system is represented by the differential equation $y'' + 3y' + 2y = r'' + 2r' + 2r$. Obtain a state (7)
model in controllable canonical form. Draw the state diagram.
- c) Obtain the state model for the given transfer function (8)

$$\frac{Y(s)}{U(s)} = \frac{1}{s^2 + s + 1}$$

- 8 a) Explain the procedure of jury test. (5)

b) The input-output relation of a sampled data system is described by the equation (7)
 $c(k+2) + 3c(k+1) + 4c(k) = r(k+1) - r(k)$. Determine the z-transfer function.

c) Determine the state transition matrix of $A = \begin{bmatrix} 0 & 1 \\ 0 & -2 \end{bmatrix}$ (8)

9 a) An electrical network is shown in fig. a Select asset of proper state variables and write down a state equation, in physical-variable form, to represent the system (10)

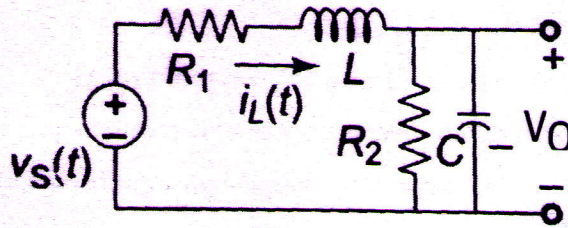

b) For the sampled data control system shown in Fig, find the response to unit step input where (10)

$$G(s) = \frac{1}{(s+1)}$$

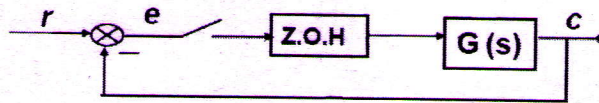

T-1 sec
