

C

B3C032S

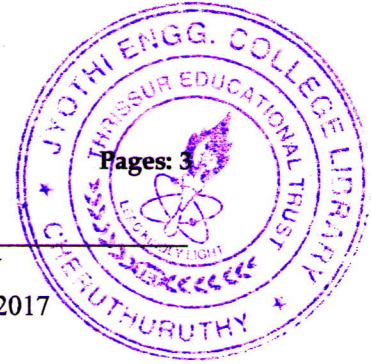

Reg. No. _____

Name: _____

APJ ABDUL KALAM TECHNOLOGICAL UNIVERSITY
THIRD SEMESTER B.TECH DEGREE EXAMINATION, JULY 2017

CE203: FLUID MECHANICS -I

Max. Marks: 100

Duration: 3Hours

PART A

Answer any two full questions.

- A wooden block of 1m side cube of relative density 0.7 floats in water. Determine the volume of concrete of relative density 2.5 that needs to be placed on it so that the block is just immersed in water. (8)
 - A single column vertical manometer with a reservoir to is connected to a pipe containing oil of specific gravity 0.9. The area of reservoir is 100 times the area of the manometric tube. The reservoir contains mercury of specific gravity 13.6. The level of mercury in the reservoir is at depth 30cm below the centre of pipe. If the difference of mercury levels in the reservoir and the right limb is 50cm, calculate the pressure in the pipe. (7)

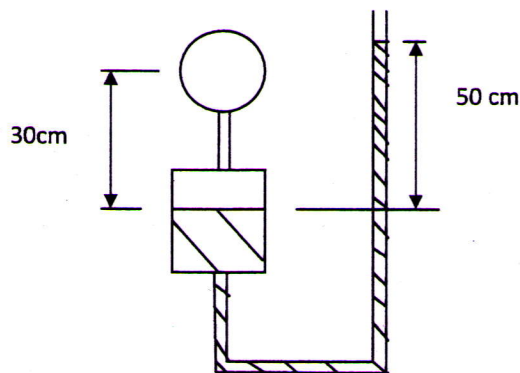

- A circular plate of 0.3m diameter is immersed in water at an inclination 60° to the free surface with its top edge at 1m below the water surface. Find the total pressure and the centre of pressure on the plate. (7)

- b. Show that $u = 3x + y$ and $v = 2x - 3y$ are the velocity components of a fluid flow. Also find the circulation around a rectangle $A(-2, 0)$, $B(2, 0)$, $C(2, 2)$, $D(-2, 2)$ (8)
3. A pipe diameter changes from 0.5m to 1m in a length of 0.785m³/s flows from 0.5m diameter section towards 1m diameter section. Determine the convective acceleration at 0.3m from the entrance. If the discharge is increased from 0.785m³/s to 1.570m³/s in 10 seconds, determine the total acceleration at the exit. (15)

PART B

Answer any two full questions.

4. a. Water under pressure of $4 \times 10^{-3} \text{ N/m}^2$ is flowing through a pipe at the rate of $0.25 \text{ m}^3/\text{s}$. If the pipe is bent such that the internal angle between the two limbs of the bend is 135° , find the magnitude and direction of the resultant force on the bend. (10)
- b. What is Cippoletti weir? Show how the effect of end contraction is compensated in a Cippoletti weir. (5)
5. A rectangular tank resting on ground is filled with water for a depth of 10m. There are two orifices on the side of the tank, one at 2m below the water surface and the other at a height of y from the bottom. The water jets coming out of the two orifices strike on the ground such that $x_2 = \frac{3x_1}{4}$ as shown in the figure. Find the value of y

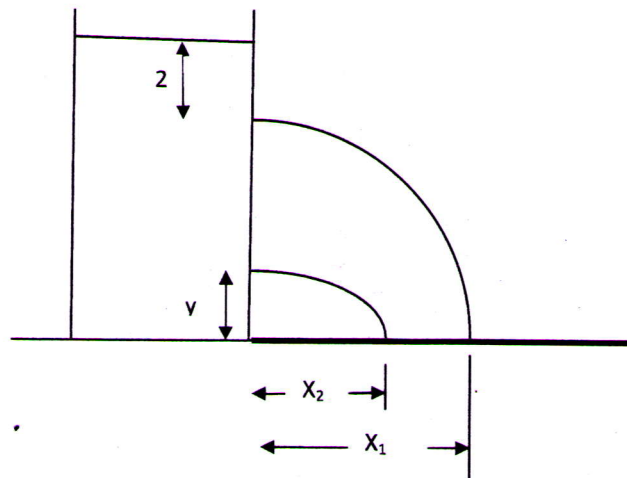

(15)

6. a. A submerged weir 2m long has height of water on the upstream 0.15m and downstream 0.075m above the top of the weir. Find the discharge over the weir, if the coefficients of discharge for free and drowned portions are 0.58 and 0.8 respectively. (8)
- b. Oil of specific gravity 0.75 flows through a 15cm diameter pipe under a pressure of 98.1kN/m^2 . If the datum is 3m below the centre of the pipe and the total energy per unit weight with respect to datum is 20m, calculate the discharge (7)

PART C

Answer any two full questions.

7. Derive the Hagen – Poiseuille equation for laminar flow through a pipe. (20)
8. Two reservoirs with a difference in water levels of 180m are connected by a 64km long pipe of 600mm diameter and darcy's friction factor $f = 0.015$. Determine the discharge through the pipe. In order to increase this discharge by 50% another additional pipe of the same diameter is laid from the first pipe and connected to the reservoir. Determine the length of the additional pipe. (20)

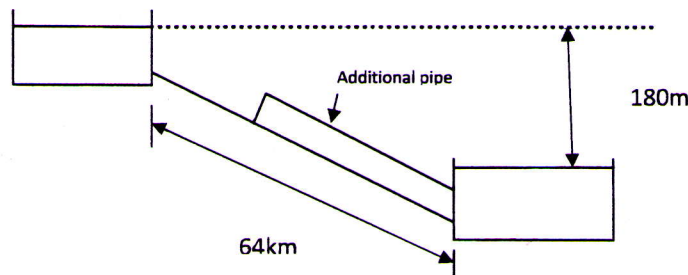

9. a. A rectangular flat plate of length a and width b is towed length-wise through water with velocity U_a and subsequently width-wise with velocity U_b . The boundary layer is laminar and the plate experiences equal drag in both cases. Determine the ratio of velocities U_a and U_b in terms of dimensions of the plate. (10)
- b. Water is delivered by a 15cm diameter pipe at 60 litres per second. Calculate the pressure difference between two points 300m apart on the same horizontal line. (10)
- (Take friction factor = 0.022)
