

10124

Reg. No.: \_\_\_\_\_

Name: \_\_\_\_\_



APJ ABDUL KALAM TECHNOLOGICAL UNIVERSITY  
FIRST SEMESTER B.TECH DEGREE SPECIAL EXAMINATION, SEPTEMBER 2015

Course Code: BE101-04

Course Name: INTRODUCTION TO ELECTRONICS ENGINEERING

Max. Marks: 100

Duration: 3 Hours

## PART A

*Answer ALL questions. Each question carries 2 marks*

- Why is it necessary to connect an electrolytic capacitor in a circuit with correct polarity?
- Write the color code for  $100\Omega$  Resistor with tolerance  $\pm 5\%$ .
- What are the specifications of transformer?
- Why does an intrinsic semiconductor behave like an insulator at absolute zero temperature?
- Explain why LEDs emit different colours.
- Identify the diodes i)AA113 ii)BB105
- “For better operation of transistor amplifiers operating point is fixed at the middle of active region”. Justify it.
- For CB input characteristic  $I_E$  vs.  $V_{EB}$  curves move inwards for higher values of  $V_{CB}$ . Justify.
- Suppose you have a single stage amplifier. Assume you removed the bypass capacitor at the emitter terminal. How does it affect the frequency response characteristics?
- What is meant by the threshold voltage of a MOSFET?
- What is intrinsic standoff ratio of UJT?
- How UJT can be used to trigger an SCR?
- What is SMPS and where it is used?
- For the given clipper circuit input is 10V peak to peak sine wave. Plot the output waveform.  $V_B = 3V$  (Fig 1)

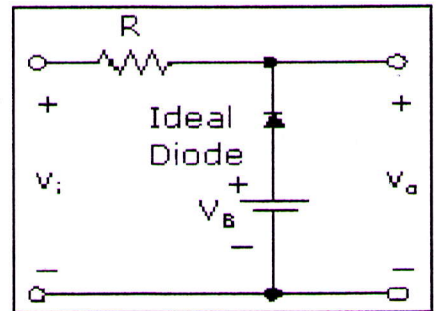

Fig 1

- For the given circuit, find out  $V_a$ . (Assume the diode to be a practical one) (Fig 2)
- Calculate the ripple factor of a capacitor filter for a peak rectified voltage of 30V, capacitor  $C=100\mu F$ , and load current of 50mA.
- Digital multimeters are superior to analog multimeters. Give reason.

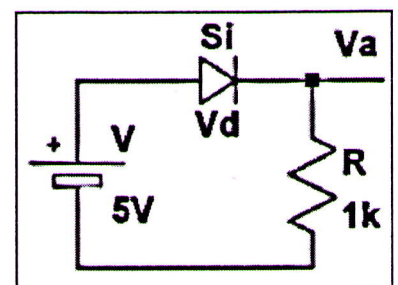

Fig 2

18. List the different types of errors in measurements.
19. Write the steps for testing a transistor.
20. Determine the phase shift between two sine waves, which is indicated by the pattern as in fig 3.

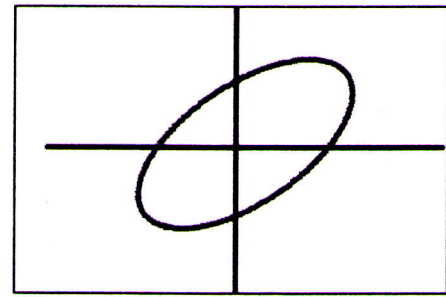

Fig 3

### PART B

*Answer any 4 complete questions each having 10 marks*

21. Explain the structure of any three types of fixed resistors. Mention its advantages and disadvantages.
22. A) Draw the V-I characteristics of a p-n junction diode. If the reverse saturation current of a Germanium pn junction diode at room temperature is  $6\mu\text{A}$ . Determine the current flowing through the diode when 0.2 V forward bias is applied. Given thermal voltage  $V_T = KT/q = 26\text{ MV}$ .  
B) A doorbell requires 0.4A at 6 V. It is connected to a transformer whose primary contains 2000 turns and is connected to a 110 V household outlet.
  1. How many turns should be there in the secondary?
  2. Find the current in the primary?
  3. How many watts does the bell require from the transformer?

23. Sketch and explain the typical input- output characteristics of a BJT when connected in
  - (i) Common Emitter configuration and
  - (ii) Common Base configuration

24. a) Find out the Q point for the transistor circuit shown in fig 4. (5 marks)

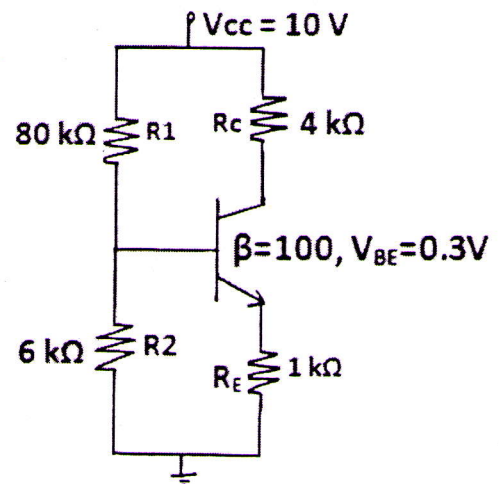

Fig 4

- b) With the help of schematic block diagram, explain the principle operation of a photo transistor. (5 marks)

25. a) Draw and explain the working of enhancement mode MOSFET. (5 marks)

- b) With a neat diagram explain the principle of operation of SCR. (5 marks)

*Answer any 2 complete questions each having 10 marks*

26. a) Discuss a full wave voltage doubler with circuit diagram. (4 marks)

b) The load resistance of a centre tapped FWR is  $500\Omega$  and the necessary voltage (end to end) is  $60 \sin(100\pi t)$ . Calculate (i) peak, average and rms values of current, (ii) ripple factor and (iii) efficiency of the rectifier. Each diode has an idealised I-V characteristics having slope corresponding to a resistance of  $50\Omega$ . (6 marks)

27. a) Draw the output waveform and transfer characteristics of the given clipper circuit: (5 marks)

b) With neat block diagram, explain the working of DSO. (5 marks)

28. a) With the aid of a block diagram, explain the working of a CRO. Also give the constructional details of cathode ray tube. (7 marks)

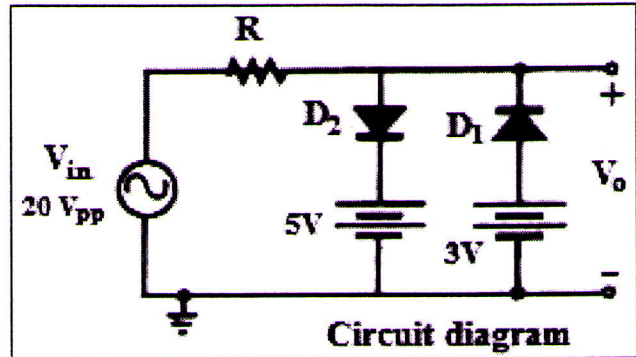

b) A sinusoidal waveform is displayed on CRO screen with one full cycle in two divisions. If the time-base knob is in  $0.5 \text{ ms}$  position, what is the frequency of the waveform?

(3 Marks)