

10120

Reg. No.: _____

Name: _____



D

APJ ABDUL KALAM TECHNOLOGICAL UNIVERSITY
FIRST SEMESTER B.TECH DEGREE SPECIAL EXAMINATION, SEPTEMBER 2016
BE101-03 INTRODUCTION TO ELECTRICAL ENGINEERING

Max. Marks: 100

Duration: 3 Hours

*Instructions: Make suitable assumptions if any data is missing
Write units in all numerical answers*

PART- A (Answer all Questions. 10x4 = 40 marks)

- 1 Determine the current supplied by the battery in the circuit shown in fig. using star delta transformation (4)

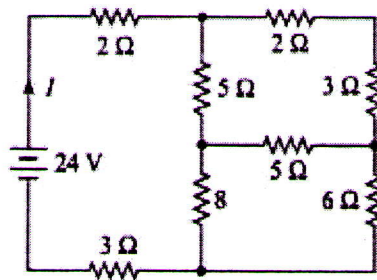

- 2 Draw and explain the characteristics of ideal and practical voltage and current sources. (4)
- 3 Distinguish between self inductance and mutual inductance and derive the expression for the self inductance of a coil. (4)
- 4 A Capacitor and resistor are connected in series across a 120 V, 50 Hz supply. The circuit draws a current of 1.144 A. If power loss in the circuit is 130.8 W, find the values of resistance and capacitance. (4)
- 5 For an ac circuit, if $v(t) = 160 \sin(\omega t + 10^\circ)$ and $i(t) = 5 \sin(\omega t - 20^\circ)$; find the power factor and active power absorbed by the circuit. Draw the phasor diagram. (4)
- 6 What is resonant frequency? A series LC circuit is resonate at 150 kHz and has a Q of 50. Find the upper and lower cutoff frequencies. (4)
- 7 What are the advantages of three phase system over single phase system? (4)
- 8 In the two wattmeter method of three phase power measurement the load connected was 50kW at 0.80 pf lagging. Find the reading of each wattmeter. (4)
- 9 Differentiate between fuse and MCB used in domestic installations. (4)
- 10 Explain the necessity of earthing in electrical appliances (4)

PART- B

Answer any four full Questions

- 11 a. How is energy stored in capacitor? On what factors does it depend? (3)
- b. Formulate the Kirchhoff's voltage law equations using mesh analysis and determine the currents I_1 , I_2 , and I_3 in the circuit shown in figure. (7)

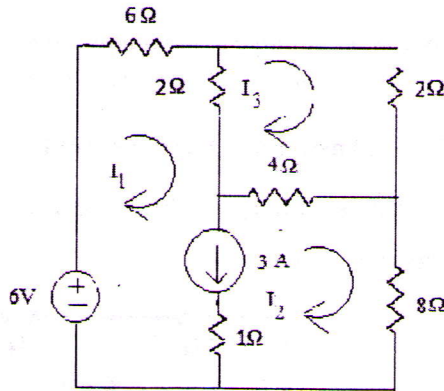

- 12 a. Find V_0 for the circuit shown in figure below using nodal analysis. (6)

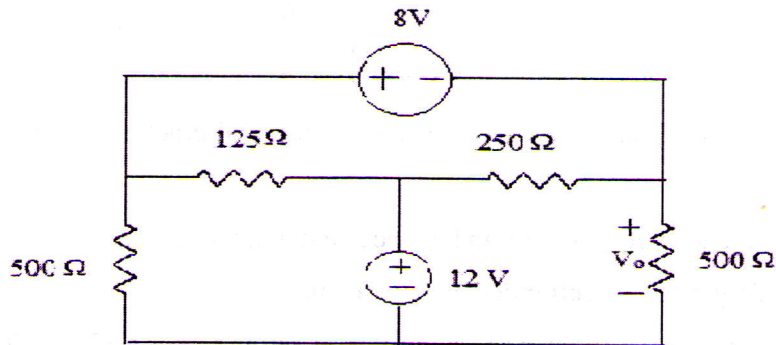

- b. Give a few similarities and dissimilarities of electric circuits and magnetic Circuit. (4)
- 13 An iron ring has a diameter of 21 cm and a cross sectional area of 10 cm^2 . The ring is made up of semicircular sections of cast iron and cast steel, with joint having a reluctance producing an air gap of 0.2 mm. Find the ampere-turns required to produce a flux of 8 mWb. The relative permeability of cast steel and cast iron are 800 and 166 respectively. (10)
- 14 Find the RMS value, Average value and form factor of the waveform shown (10)

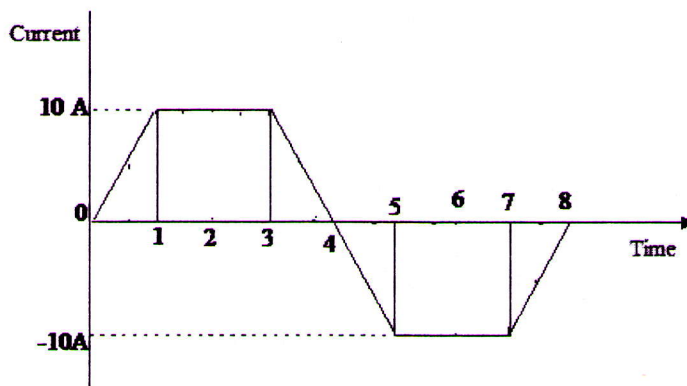

- 15 A non-inductive resistance is connected in series with a practical inductive coil. The circuit is supplied with 250 V, 50 Hz supply. When a current of 5A flows through the circuit, the magnitude of voltage drop across the resistance and coil are 125 V and 200 V respectively. Calculate (i) the impedance, resistance and reactance of the coil (ii) Power absorbed by the coil and (iii) Total power. Also draw the phasor diagram (10)
- 16 a. Calculate the value of R in the circuit shown in figure such that the circuit will resonate (4)

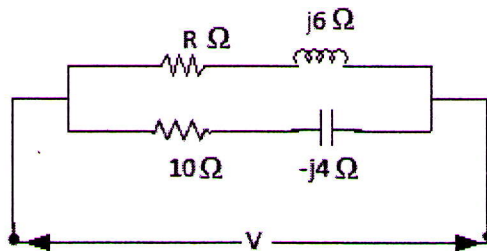

- b. Two coils A and B are connected in series across a 240 V, 50 Hz ac supply. The resistance of A is 5Ω and the inductance of B is 0.015 H. If the input from the supply is 3 kW and 2 kVAR, find the inductance of coil A and resistance of coil B. Calculate the voltage across each coil. (6)

PART- C

Answer two full Questions (17 or 18 and 19 or 20)

- 17 a. Derive the relation between Line and Phase Values of Voltage and Current for a star connected system. (5)
- b. A three phase star connected load consumes a total of 12 kW at a power factor of 0.8 lagging when connected to a 3 phase, 400 V, 50 Hz power supply. Calculate the resistance and inductance of load per phase. (5)

OR

- 18 a. What is phase sequence of a 3 phase system? (3)

- b. Two single phase wattmeter are used to measure three phase power. The readings of the two Watt meters are 2500 W and 450 W respectively. Calculate the Power factor of the circuit. What would be the power factor if the reading of the second wattmeter is negative? (7)
- 19 a. Give the schematic Layout of an LT Switch Board (5)
- b. What is the role of an ELCB in domestic wiring circuit? Also explain the working of ELCB (5)
- OR**
- 20 With a neat sketch, explain pipe earthing indicating required dimensions. (10)
-