

C 40928

(Pages : 2)

Name.....

Reg. No.....

**COMBINED FIRST AND SECOND SEMESTER B.TECH. (ENGINEERING)  
DEGREE EXAMINATION, APRIL 2013**

EN 09 108 (A)—ENGINEERING GRAPHICS (A)

(2009 Scheme—Regular/Supplementary/Improvement)

(For AE, AN, AU, BT, EC, EEE, IC, PE, PT)



Time : Three Hours

Maximum : 70 Marks

Answer **three** questions from Part A and any **two** questions from Part B.

All questions carry equal marks.

**Part A**

1. (a) A line AB, 65 mm long has its end A, 25 mm above the HP and 20 mm in front of the VP. The end B is 40 mm above the HP and 50 mm in front of the VP. Draw its projection and find its inclinations with HP and VP. Also locate its traces.

Or

- (b) Draw the projections of a line PQ 70 mm. inclined at  $30^\circ$  to the HP and  $40^\circ$  to the VP. The end P of the line is 25 mm. above HP and 30 mm. in front of VP. Also mark the angle made by the line with the  $xy$ -line.
2. (a) A pentagon of side 30 mm. rests on the ground on one of its sides inclined at  $30^\circ$  to the V.P. The surface of the pentagon makes an angle of  $50^\circ$  with the ground. Draw the top and front views of the pentagon.

Or

- (b) A solid hexagonal pyramid of base side 25 mm and height 60 mm is suspended freely by means of string attached to one corner of the base of the pyramid. The axis of the pyramid is parallel to the V.P. Draw the projections of the pyramid.
3. (a) A cone of base diameter 60 mm. and height 80 mm. is resting on its base on the H.P. It is cut by a section plane inclined at  $40^\circ$  to the H.P. and passing through a point which is 40 mm. below the vertex of the cone. Draw the front view, sectional top view and true shape of the section.

Or

- (b) A square pyramid of side 50 mm. and height 65 mm. rests on its base on the HP such that one of its sides of the base is parallel to VP. The axis of the pyramid is cut by a section plane at 25 mm. above the base. The section plane is inclined at  $45^\circ$  to the right of the axis. Draw the development of the lower portions of the surface of the pyramid.

(3 × 14 = 42 marks)

Turn over

## Part B

4. A sphere of radius 20 mm is kept on the top face of a square prism of side of base 40 mm and height 20 mm. The latter is placed on the top face of a cylinder of 65 mm diameter and 25 mm height. All the three solids have the common axis. Draw the isometric projection.
5. A hexagonal lamina of 25 mm. side stands vertically on the ground plane and inclined at  $50^\circ$  to PP. The corner nearest to PP is 20 mm behind it. The station point is 45 mm. in front of PP, 50 mm. above the ground plane and lies in a central plane which passes through the center of lamina. Draw the perspective view.
6. Draw the dimensioned orthographic views (all three) of the object shown in Figure 1.

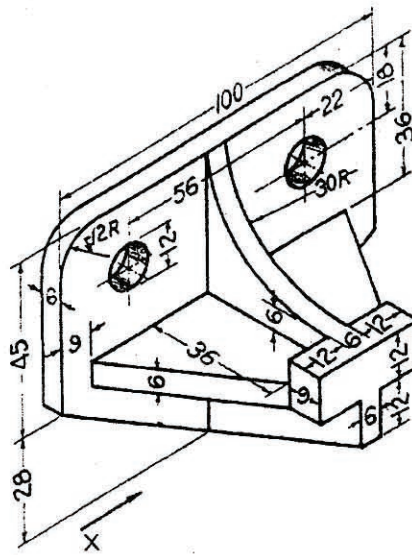

Figure 1

(2 × 14 = 28 marks)