

Reg No.: \_\_\_\_\_

Name: \_\_\_\_\_

1100ECT307122102  
APJ ABDUL KALAM TECHNOLOGICAL UNIVERSITY

B.Tech Degree S5 (R, S) / S3 (PT) (R, S) Examination December 2023 (2019 Scheme)



Course Code: ECT 307  
Course Name: CONTROL SYSTEMS

Max. Marks: 100

Duration: 3 Hours

**PART A**

*(Answer all questions; each question carries 3 marks)*

Marks

- 1 Draw the basic block diagram for a closed loop control system. What are the advantages of closed loop control system over open loop control system 3
- 2 Define the term "state" in the state variable representation. Write the state equation and output equation for a linear system. 3
- 3 Write the time domain and Laplace domain expressions of unit step, unit ramp, and unit parabolic test inputs. 3
- 4 Explain the term determinant of a signal flow graph. Where does it appear in a transfer function? 3
- 5 Define the BIBO stability. What is the condition on the impulse response for stability? 3
- 6 Define the angle and magnitude criteria of root locus on the open-loop transfer function of a system. 3
- 7 Draw the s-plane contour used for mapping, for stability analysis, to the plane of open-loop transfer function. 3

$$G(s)H(s) = \frac{1}{s(s+1)}$$

Explain the choice of the contour.

- 8 Derive and plot the response of a first order unity negative feedback system to unit step input. 3
- 9 Find the state equation for the system represented by the differential equation 3

$$\frac{d^2y}{dt^2} + 20\frac{dy}{dt} + 100y = u(t)$$

where,  $u(t)$  is the input and  $y(t)$  is the output. Take zero initial conditions.

1100ECT307122102

- 10 Write the transfer function of a first order phase lead compensator. State the function of a phase lead compensator in a control system. 3

PART B

(Answer one full question from each module, each question carries 14 marks)

Module -1

- 11 a) Draw the schematic of a second order spring-mass-damper (SMD) system and obtain its transfer function. Draw the Force current analogy circuit of the system. 4  
 b) Find the transfer function of the following block diagram using block diagram reduction technique. Verify the same using SFG and mason's gain formula 10

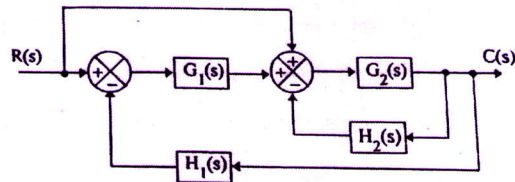

12 a)

10

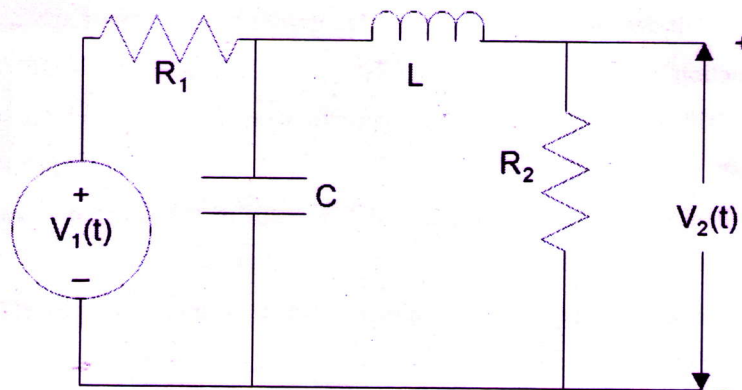

Draw the block diagram of the electrical network shown in figure. Find the transfer function  $\frac{V_2(s)}{V_1(s)}$  by applying direct block diagram reduction rules to the obtained block diagram

- b) Draw the signal flow graph for the system in question 12 (a) and obtain the transfer function using the Mason's Formula. 4

## 1100ECT307122102

### Module -2

- 13 a) Write the expression for transfer function of a general second order system with negative feedback and complex poles in the standard form. Find roots of the characteristic equation of the system. 7
- b) For an under damped second order system with complex poles on the left half of s-plane, derive the expression for rise time, percentage peak overshoot and steady state error parameters. 7
- 14 a) For the system in the block diagram, 7

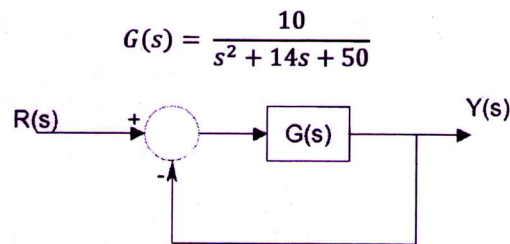

Find the steady state error values for unit step and unit ramp inputs.

- b) Plot the poles of the system in 14(a) and find the percentage overshoot of output. 7

### Module -3

- 15 a) For the system having transfer function, 7

$$T(s) = \frac{-K(s-1)}{s^3 + 3s^2 + (2-K)s + K}$$

Find the range of  $K$  for which the system is stable.

- b) Plot the locus of roots for the system having the following open loop transfer function. 7

$$G(s) = \frac{K(s^2 + 4)}{s(s + 4)}$$

State all the steps for plotting the root locus.

- 16 a) Explain the effect of adding a pole and zero to a second order system 7
- b) For a system having open loop transfer function, 7

$$G(s)H(s) = \frac{K}{(s+1)(s+3)(s+6)}$$

Find the value of  $K$  when two roots lie on the imaginary axis. Also find the roots.

### Module -4

- 17 a) Using the Nyquist contour, analyse the following open loop transfer function of a 7

**1100ECT307122102**

system to obtain the limit of  $K$  for the stability.

$$G(s)H(s) = \frac{K}{s(\tau_1 s + 1)(\tau_2 s + 1)}$$

- b) Draw the bode plots of a system whose open loop transfer function is given by 7

$$G(s)H(s) = \frac{K}{s(s + 1)(s + 2)}$$

Explain how the plot can be used for analysing the absolute stability of the system.

- 18 a) State Cauchy's argument principle with the conditions to be applied on the contour 7  
of mapping. State the Nyquist criterion of stability on the open loop transfer function of a control system.

- b) Draw the Nyquist plot and check for stability of the system with open loop transfer 7  
function.

$$G(s)H(s) = \frac{3}{s(s + 1)(s + 3)}$$

Also find the gain margin for this system.

**Module -5**

- 19 a) Obtain the state model of the electrical network shown in the fig. by choosing  $v_1(t)$  7  
and  $v_2(t)$  as state variables.

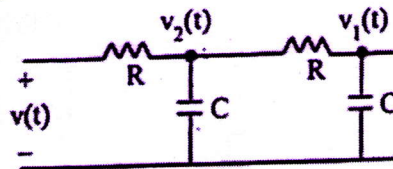

- b) Explain how to obtain transfer function from the state equations. 7

- 20 a) Obtain the state variable matrix in the phase variable form for a system with 7  
differential equation

$$2 \frac{d^3 y}{dt^3} + 4 \frac{d^2 y}{dt^2} + 6 \frac{dy}{dt} + 8y = 10u(t)$$

Draw the signal flow graph for the phase variable form. Assume zero initial conditions.

- b) A linear time invariant system is described by the state equation 7

$$\dot{X}(t) = \begin{bmatrix} -1 & 2 \\ -1 & -3 \end{bmatrix} X(t) + \begin{bmatrix} 0 \\ 1 \end{bmatrix} r(t).$$

Find the state transition matrix.

If the initial state vector is  $X(0) = \begin{bmatrix} 1 \\ 0 \end{bmatrix}$ . Obtain the zero input response.

\*\*\*\*\*